

Compacta counter top pizza oven data sheet

The ideal solution for Small Pizza Production. This oven has Two Stone Soles, which can accommodate one 14" Pizza on each level.

EACH COMPACTA PIZZA OVEN FEATURES:

- **STAINLESS STEEL**
Selected for the outer shell and baking chamber for its durability and long life properties.
- **VIENNA DOORS**
Fully insulated and full width of deck. Doors are counter-balanced and can be positioned easily at variable openings.
- **HEATING ELEMENTS**
All elements are manufactured in our own Electronics Department. As we are confident that this provides the best quality and reliability for our customers, we provide a 5 year guarantee!
- **CONTROLS**
High temperature electronic thermostat. Maximum temperature 300° C. Independent over-temperature protection.
- **TIMER**
Electronic timer for each shelf.
- **MELLOW BAKE**
The combination of ceramic tile baking sole And the expertly graded heating elements on each deck offers a truly mellow bake. The only way to cook pizza's.
- **DOUBLE STACK OPTION**
For extra capacity.
- **ELECTRICAL SUPPLY**
230V single phase 16A supply required. Maximum loading 3.6 kW. Oven supplied with 2m of cable and Commando Plug.
- **PREVENTATIVE MAINTENANCE PROGRAMME**
Our Service Department can advise on a range of maintenance and preventative maintenance programmes. Contact the Service Department on their direct line – 0161 320 6121

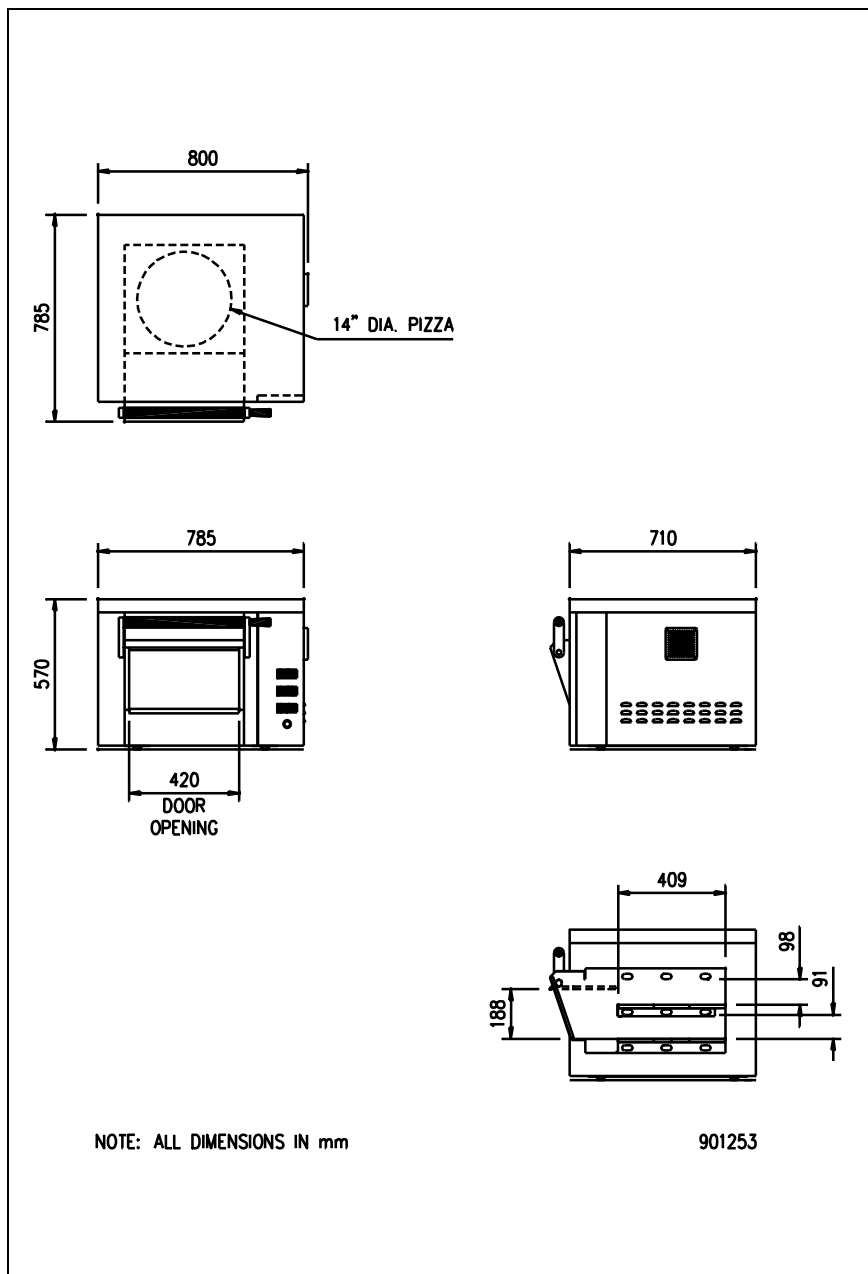

Tom Chandley Limited, Bakery Engineers
Windmill Lane, Denton, Manchester, M34 3RB, England

telephone: +44 (0) 161 336 5444
fax: +44 (0) 161 335 0972
e-mail: info@chandleyovens.co.uk
website: www.chandleyovens.co.uk