

# Panther 'L' Sealer *data sheet*

The ideal bag sealer for larger convenience stores or supermarkets. It is a semi-automatic, hot wire 'L' sealer with conveyor discharge mechanism, for bagging a wide range of bread products.

## FEATURES

- SEPARATE FILM CARRIER
- SEALING AREA:- 420 x 380mm
- ADJUSTABLE TABLE HEIGHT
- AUTOMATIC TEMPERATURE/TIMER
- AUTOMATIC CONVEYOR DISCHARGE
- REPLACEABLE SEALING PAD TAPES
- REPLACEABLE SEALING PADS
- REPLACEABLE HEATER WIRES
- CONSUMABLES KIT WITH EACH SEALER

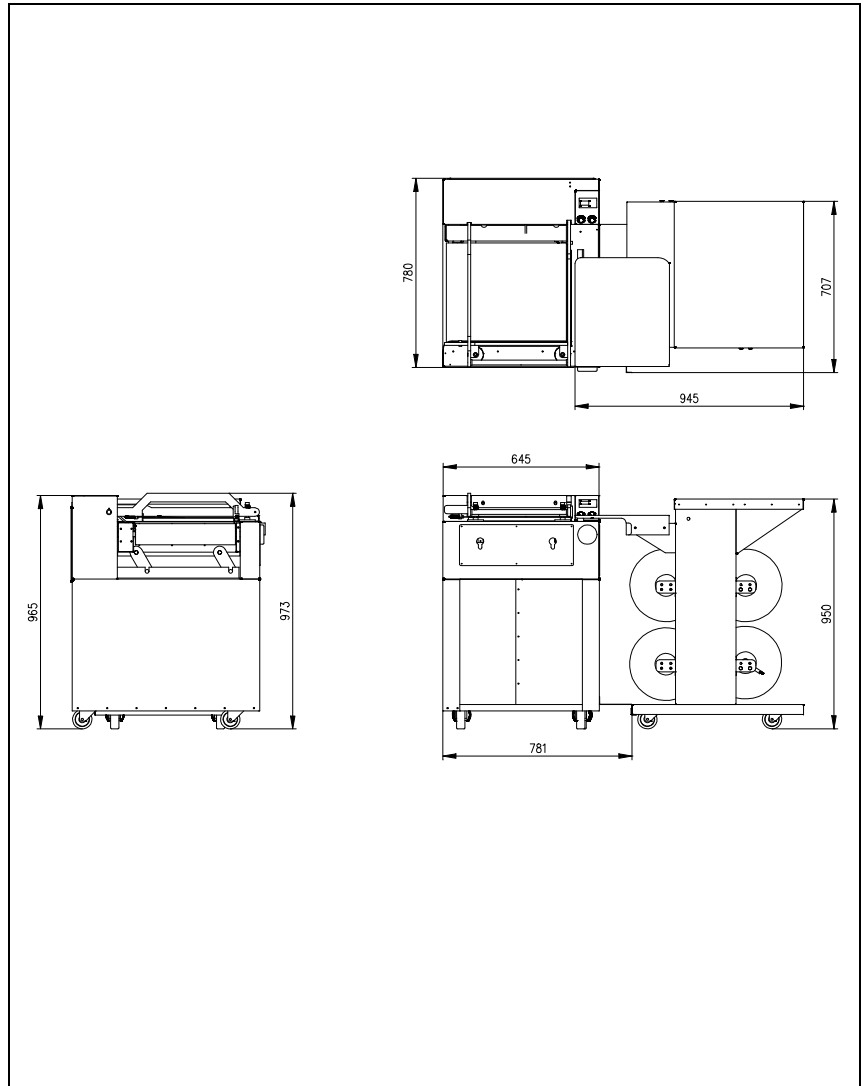

Tom Chandley Limited, Bakery Engineers  
Windmill Lane, Denton, Manchester, M34 3RB, England

telephone: +44 (0) 161 336 5444

fax: +44 (0) 161 335 0972

e-mail: [info@chandleyovens.co.uk](mailto:info@chandleyovens.co.uk)

website: [www.chandleyovens.co.uk](http://www.chandleyovens.co.uk)

