

T/c Mobile Prover data sheet

FEATURES

- SINGLE DOOR UNIT
- ADJUSTABLE FLIP-UP RUNNERS, TO SUIT ANY PRODUCT COMBINATION AS REQUIRED e.g.
18 TRAY CAPACITY @ 90mm OR
9 TRAY CAPACITY @ 180mm
- TO SUIT 30" x 18" OR 60 x 40cm TRAYS (CUSTOMER TO SPECIFY)
- HAND FILL OR AUTO FILL (CUSTOMER TO SPECIFY)
- 13A SINGLE PHASE SUPPLY
- MOBILE (ON CASTORS – FRONT LOCKING)
- CONTROLLED AIR FLOW
- INSULATED DOUBLE SKINNED CONSTRUCTION
- ELECTRONIC WATER LEVEL CONTROL (AUTOFILL MODEL)
- INTEGRATED PLUGGED DRAIN IN THE BASE FOR EASE OF CLEANING
- BRUSHED STAINLESS STEEL FINISH
- INDIVIDUAL ADJUSTABLE TEMP/HUMIDITY CONTROLS
- HIGH LEVEL CONTROLS (ABOVE DOOR)
- DOOR CAN BE HINGED LEFT OR RIGHT (CUSTOMER TO SPECIFY)

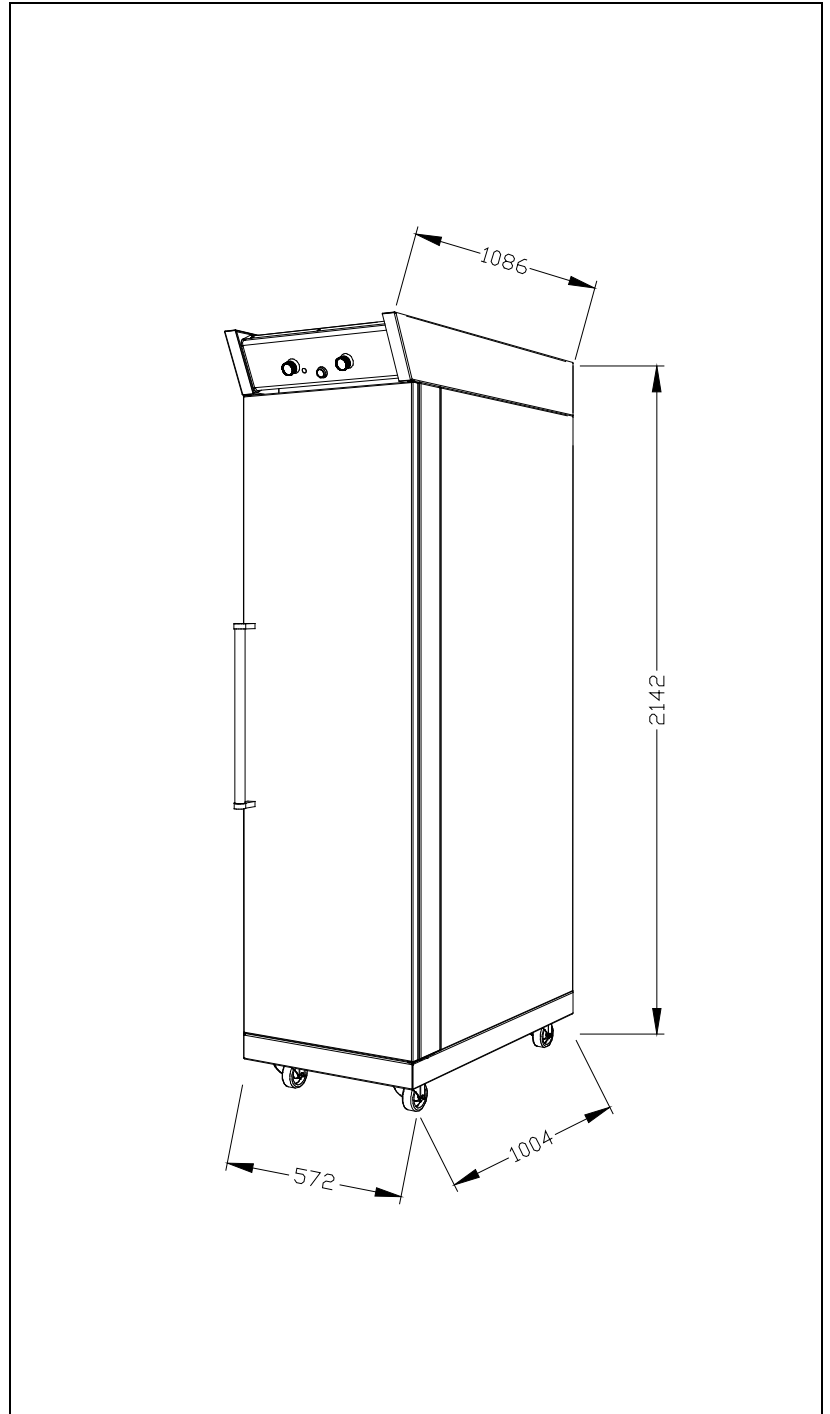

Tom Chandley Limited, Bakery Engineers
Windmill Lane, Denton, Manchester, M34 3RB, England

telephone: +44 (0) 161 336 5444

fax: +44 (0) 161 335 0972

e-mail: info@chandleyovens.co.uk

website: www.chandleyovens.co.uk